

**OptiMOS™-T2 Power-Transistor**

**Product Summary**

$V_{DS}$	100	V
$R_{DS(on)}$	2.5	mΩ
$I_D$	180	A

**Features**

- N-channel - Enhancement mode
- AEC Q101 qualified
- MSL1 up to 260°C peak reflow
- 175°C operating temperature
- RoHS compliant
- 100% Avalanche tested

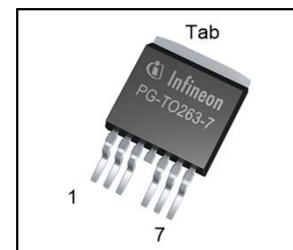
**PG-TO263-7-3**

Type	Package	Marking
IPB180N10S4-02	PG-TO263-7-3	4N1002

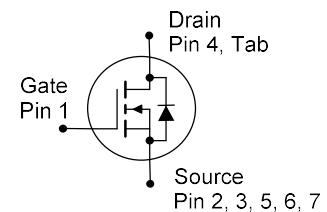
**Maximum ratings**, at  $T_j=25\text{ °C}$ , unless otherwise specified

Parameter	Symbol	Conditions	Value	Unit
Continuous drain current	$I_D$	$T_C=25\text{ °C}, V_{GS}=10\text{V}^{(1)}$	180	A
		$T_C=100\text{ °C}, V_{GS}=10\text{V}^{(2)}$	171	
Pulsed drain current <sup>2)</sup>	$I_{D,pulse}$	$T_C=25\text{ °C}$	720	
Avalanche energy, single pulse <sup>2)</sup>	$E_{AS}$	$I_D=90\text{A}$	1110	mJ
Avalanche current, single pulse	$I_{AS}$	-	180	A
Gate source voltage	$V_{GS}$	-	±20	V
Power dissipation	$P_{tot}$	$T_C=25\text{ °C}$	300	W
Operating and storage temperature	$T_j, T_{stg}$	-	-55 ... +175	°C
IEC climatic category; DIN IEC 68-1	-	-	55/175/56	

Parameter	Symbol	Conditions	Values			Unit
			min.	typ.	max.	

**Thermal characteristics<sup>2)</sup>**

Thermal resistance, junction - case	$R_{thJC}$	-	-	-	0.5	K/W
SMD version, device on PCB	$R_{thJA}$	minimal footprint	-	-	62	
		6cm <sup>2</sup> cooling area <sup>3)</sup>	-	-	40	

**Electrical characteristics, at  $T_j=25^\circ\text{C}$ , unless otherwise specified**
**Static characteristics**

Drain-source breakdown voltage	$V_{(BR)DSS}$	$V_{GS}=0V, I_D=1mA$	100	-	-	V
Gate threshold voltage	$V_{GS(th)}$	$V_{DS}=V_{GS}, I_D=275\mu A$	2.0	2.7	3.5	
Zero gate voltage drain current	$I_{DSS}$	$V_{DS}=100V, V_{GS}=0V, T_j=25^\circ\text{C}$	-	0.1	1	$\mu A$
		$V_{DS}=100V, V_{GS}=0V, T_j=125^\circ\text{C}^{2)}$	-	10	100	
Gate-source leakage current	$I_{GSS}$	$V_{GS}=20V, V_{DS}=0V$	-	-	100	nA
Drain-source on-state resistance	$R_{DS(on)}$	$V_{GS}=10V, I_D=100A$	-	2.0	2.5	m $\Omega$

Parameter	Symbol	Conditions	Values			Unit
			min.	typ.	max.	

**Dynamic characteristics<sup>2)</sup>**

Input capacitance	$C_{iss}$	$V_{GS}=0V, V_{DS}=25V,$ $f=1MHz$	-	11240	14600	pF
Output capacitance	$C_{oss}$		-	3660	4760	
Reverse transfer capacitance	$C_{rss}$		-	230	460	
Turn-on delay time	$t_{d(on)}$	$V_{DD}=50V, V_{GS}=10V,$ $I_D=180A, R_G=1.6\Omega$	-	15	-	ns
Rise time	$t_r$		-	9	-	
Turn-off delay time	$t_{d(off)}$		-	30	-	
Fall time	$t_f$		-	40	-	

**Gate Charge Characteristics<sup>2)</sup>**

Gate to source charge	$Q_{gs}$	$V_{DD}=80V, I_D=180A,$ $V_{GS}=0 \text{ to } 10V$	-	52	68	nC
Gate to drain charge	$Q_{gd}$		-	30	60	
Gate charge total	$Q_g$		-	156	200	
Gate plateau voltage	$V_{plateau}$		-	4.7	-	V

**Reverse Diode**

Diode continuous forward current <sup>2)</sup>	$I_S$	$T_C=25^\circ C$	-	-	180	A
Diode pulse current <sup>2)</sup>	$I_{S,pulse}$		-	-	720	
Diode forward voltage	$V_{SD}$	$V_{GS}=0V, I_F=100A,$ $T_J=25^\circ C$	-	1.0	1.2	V
Reverse recovery time <sup>2)</sup>	$t_{rr}$	$V_R=50V, I_F=50A,$ $di_F/dt=100A/\mu s$	-	100	-	ns
Reverse recovery charge <sup>2)</sup>	$Q_{rr}$		-	230	-	nC

<sup>1)</sup> Current is limited by bondwire; with an  $R_{thJC} = 0.5K/W$  the chip is able to carry 242A at 25°C.

<sup>2)</sup> Defined by design. Not subject to production test.

<sup>3)</sup> Device on 40 mm x 40 mm x 1.5 mm epoxy PCB FR4 with 6 cm<sup>2</sup> (one layer, 70 μm thick) copper area for drain connection. PCB is vertical in still air.

**1 Power dissipation**

$P_{tot} = f(T_C); V_{GS} \geq 6\text{ V}$

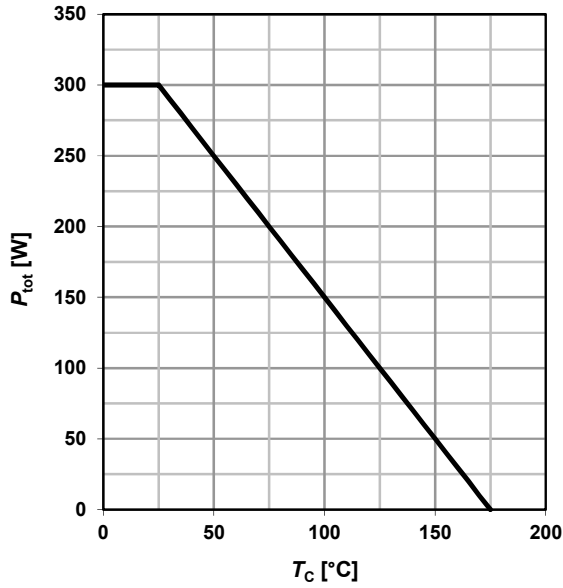

**2 Drain current**

$I_D = f(T_C); V_{GS} \geq 6\text{ V}$

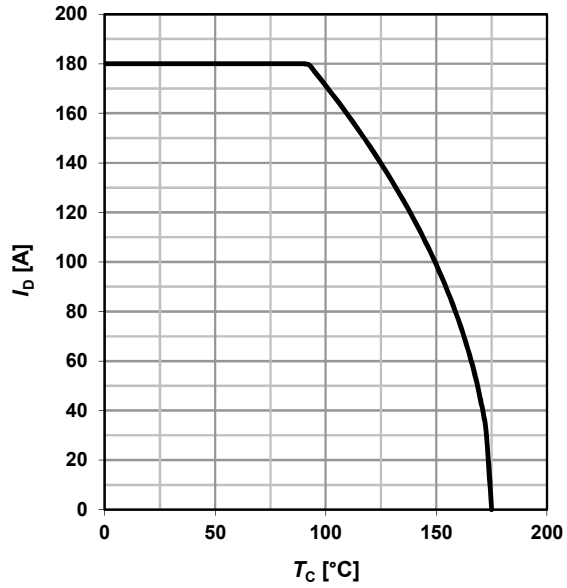

**3 Safe operating area**

$I_D = f(V_{DS}); T_C = 25\text{ °C}; D = 0$

parameter:  $t_p$

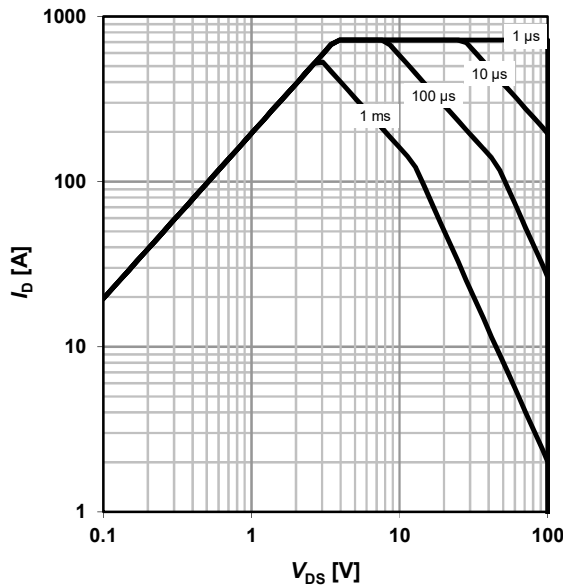

**4 Max. transient thermal impedance**

$Z_{thJC} = f(t_p)$

parameter:  $D = t_p/T$

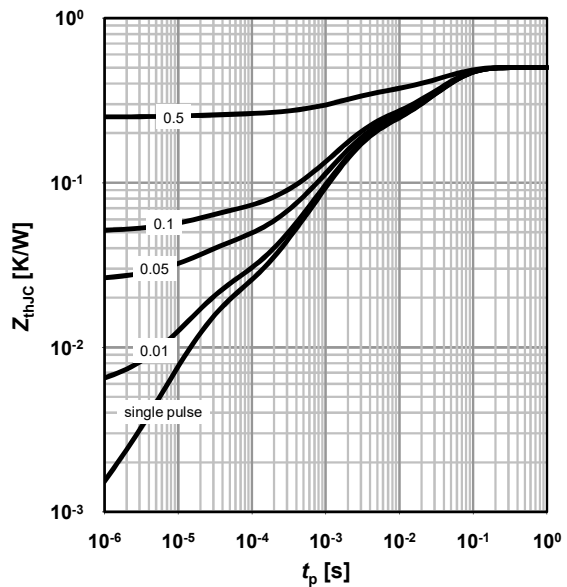

**5 Typ. output characteristics**

$I_D = f(V_{DS}); T_j = 25\text{ }^\circ\text{C}$

parameter:  $V_{GS}$

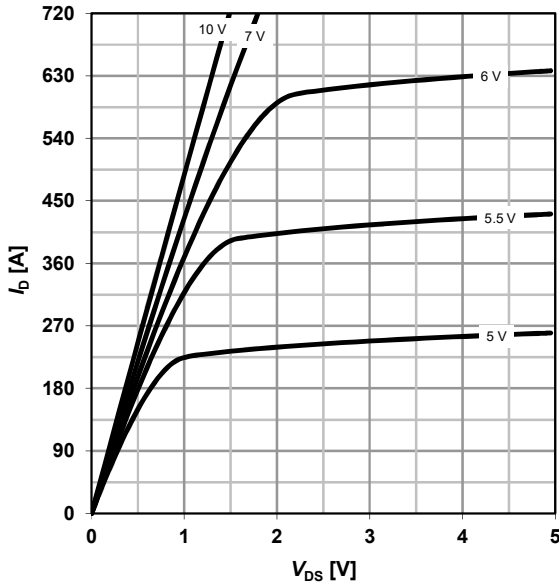

**6 Typ. drain-source on-state resistance**

$R_{DS(on)} = f(I_D); T_j = 25\text{ }^\circ\text{C}$

parameter:  $V_{GS}$

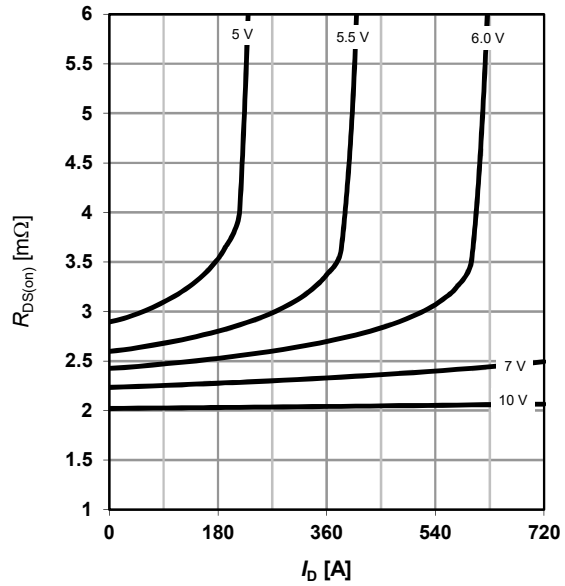

**7 Typ. transfer characteristics**

$I_D = f(V_{GS}); V_{DS} = 6\text{ V}$

parameter:  $T_j$

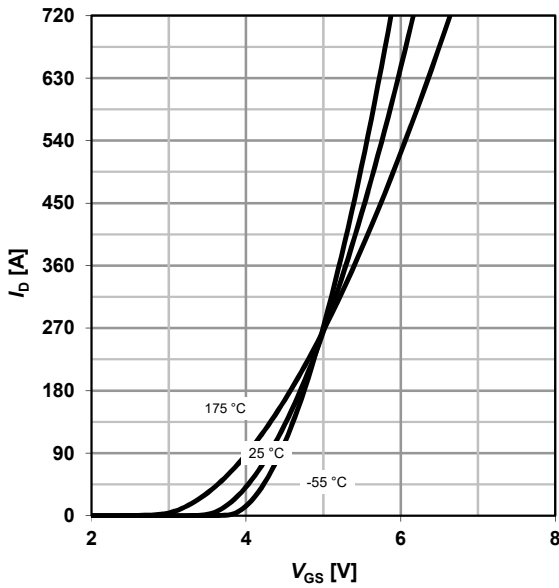

**8 Typ. drain-source on-state resistance**

$R_{DS(on)} = f(T_j); I_D = 100\text{ A}; V_{GS} = 10\text{ V}$

$\alpha = 0.4$

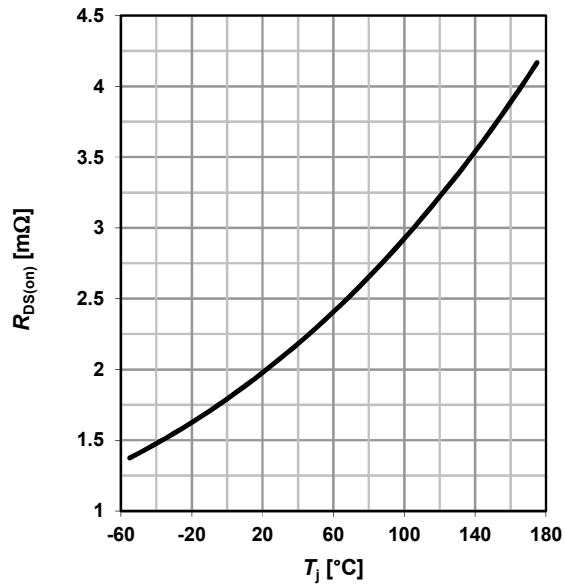

**9 Typ. gate threshold voltage**

$V_{GS(th)} = f(T_j); V_{GS} = V_{DS}$

parameter:  $I_D$

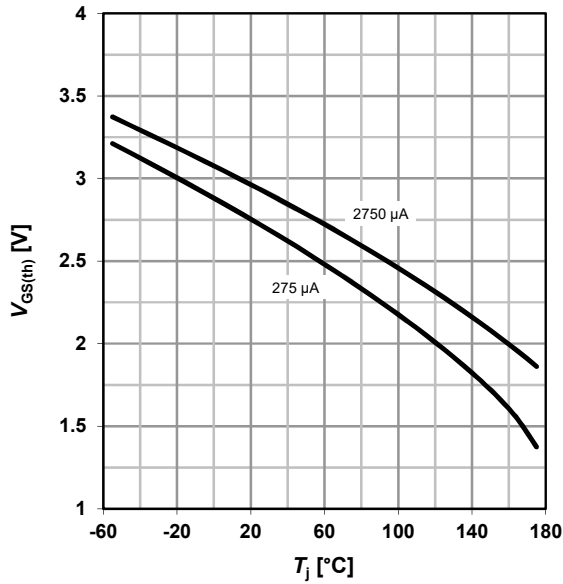

**10 Typ. capacitances**

$C = f(V_{DS}); V_{GS} = 0 V; f = 1 MHz$

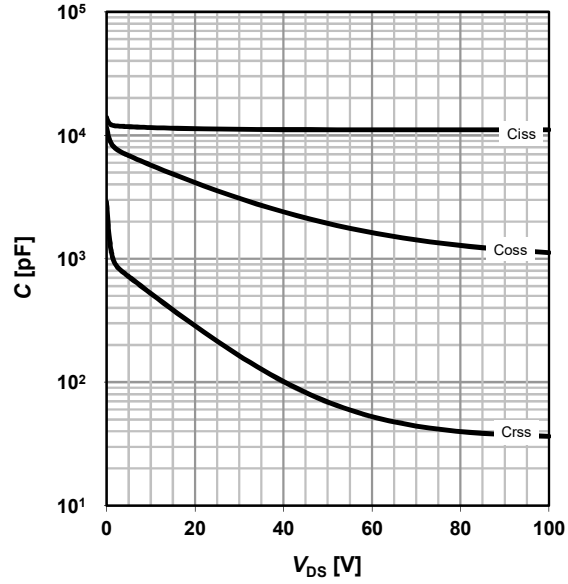

**11 Typical forward diode characteristics**

$I_F = f(V_{SD})$

parameter:  $T_j$

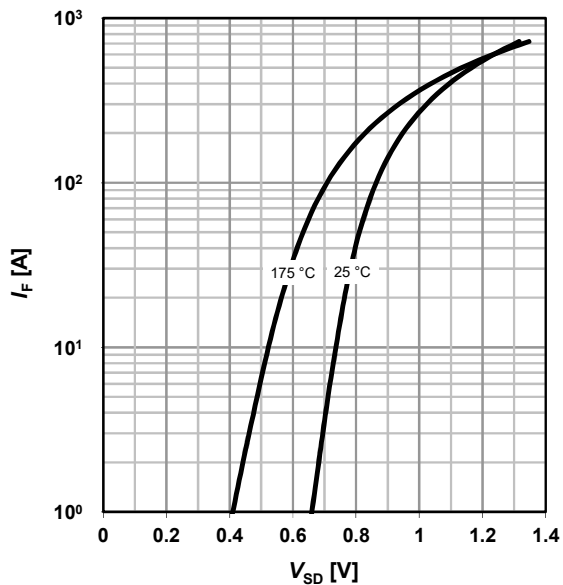

**12 Typ. avalanche characteristics**

$I_{AS} = f(t_{AV})$

parameter:  $T_{j(start)}$

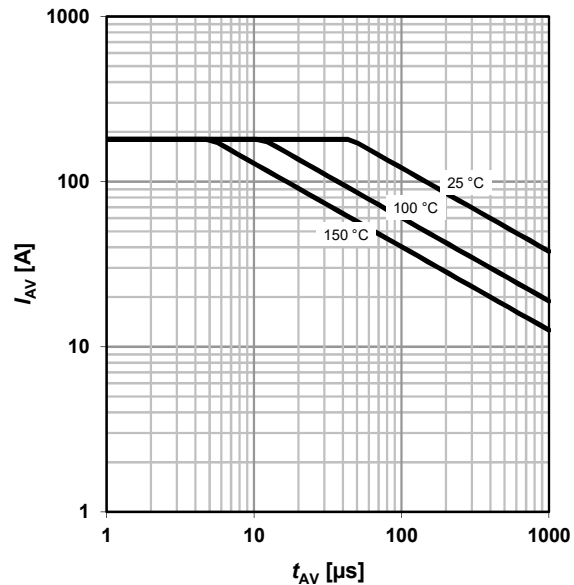

**13 Typical avalanche energy**

$E_{AS} = f(T_j)$

parameter:  $I_D$

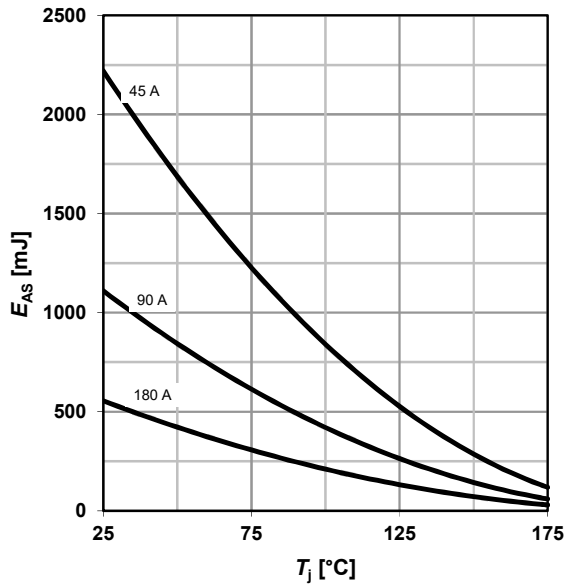

**14 Drain-source breakdown voltage**

$V_{BR(DSS)} = f(T_j); I_D = 1 \text{ mA}$

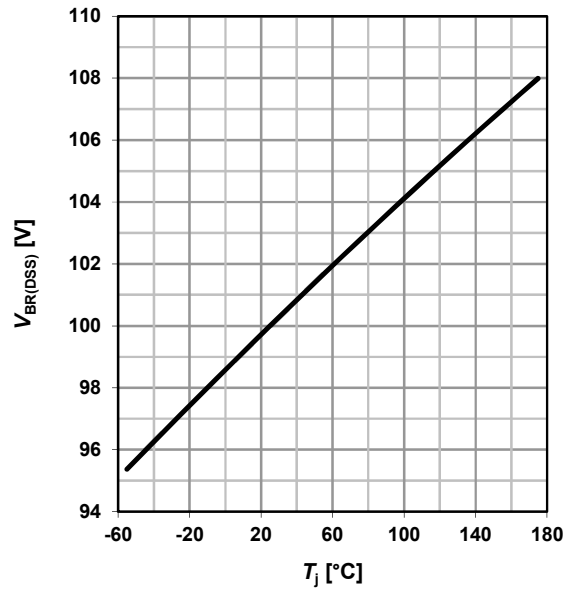

**15 Typ. gate charge**

$V_{GS} = f(Q_{gate}); I_D = 180 \text{ A pulsed}$

parameter:  $V_{DD}$

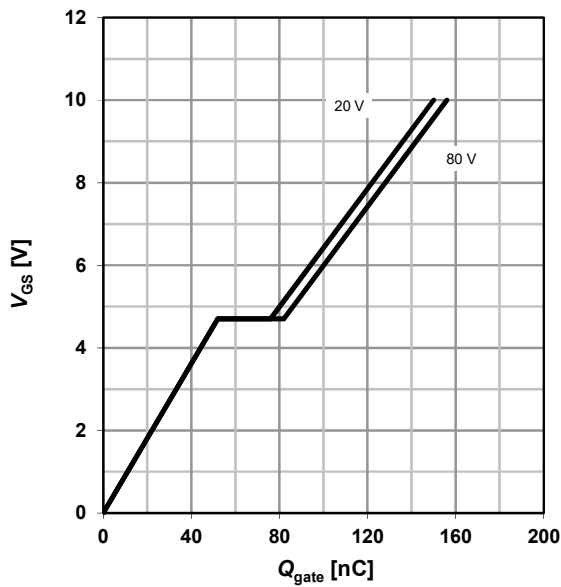

**16 Gate charge waveforms**

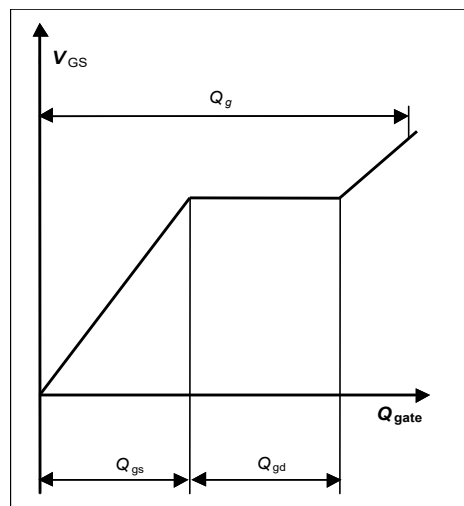

Package Outline

P-TO263-3-2: Outline

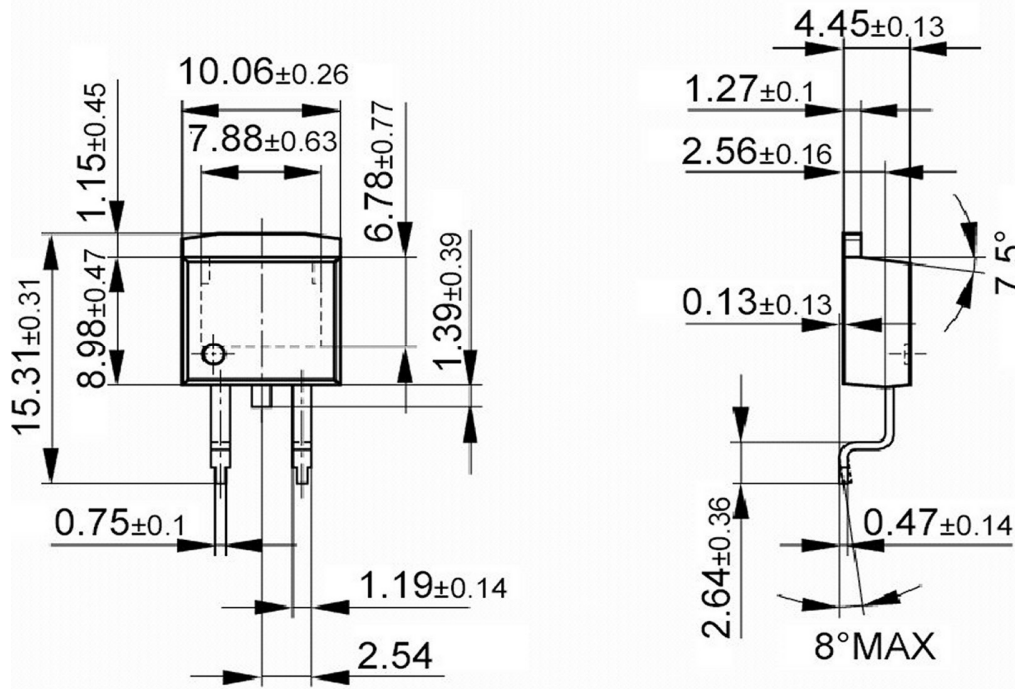

Footprint

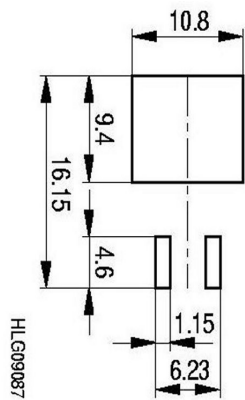

Packaging

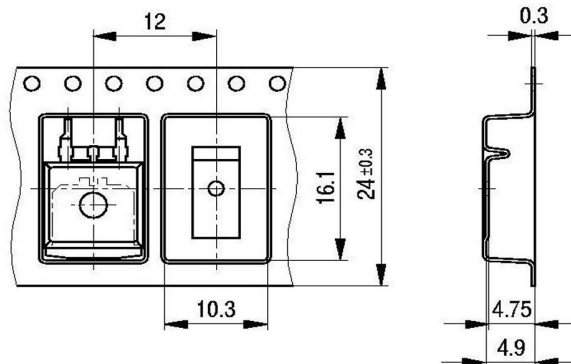



P-TO262-3-1: Outline

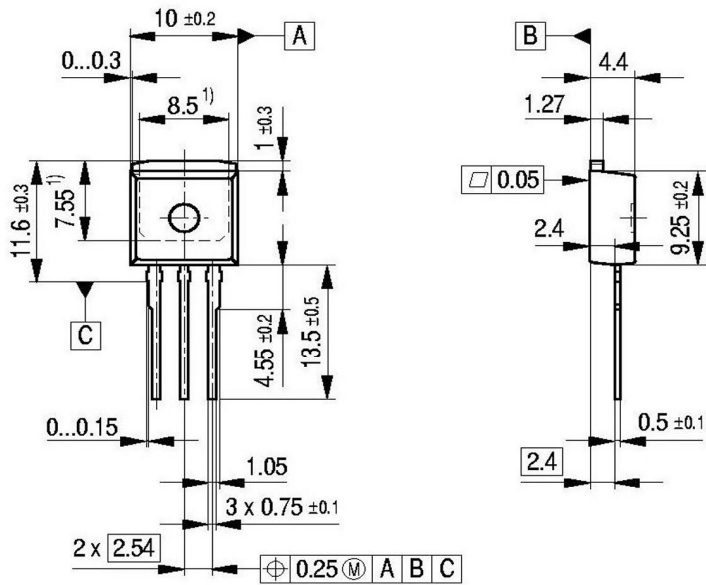

1) Typical  
 Metal surface min. X = 7.25, Y = 6.9  
 All metal surfaces tin plated, except area of cut.

P-TO220-3-1: Outline

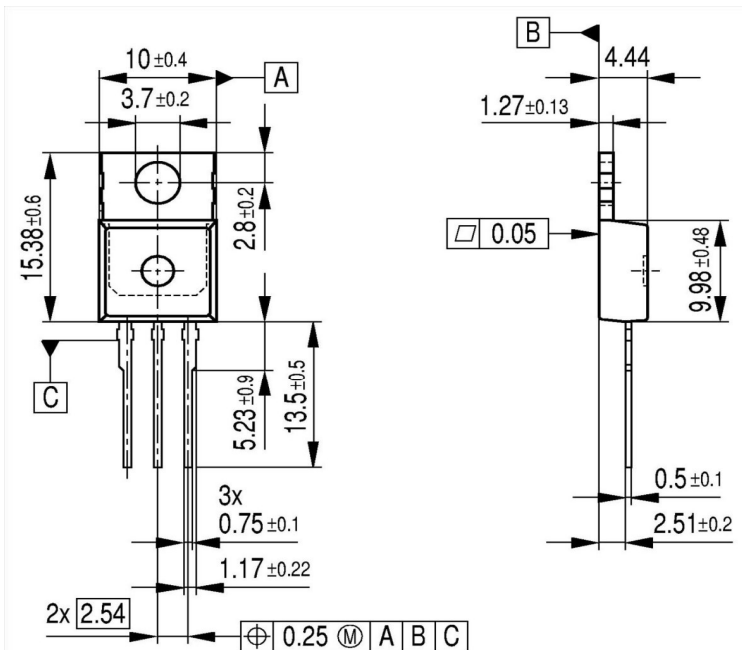

All metal surfaces tin plated, except area of cut.  
 Metal surface min. x=7.25, y=12.3

Packaging

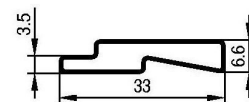

Dimensions in mm

**Trademarks**

All referenced product or service names and trademarks are the property of their respective owners.

**Edition 2023-01-30****Published by****Infineon Technologies AG****81726 Munich, Germany****© 2023 Infineon Technologies AG****All Rights Reserved.****Do you have any questions about any aspect of this document?****Email: [erratum@infineon.com](mailto:erratum@infineon.com)****Document reference  
IB180N10S4-02-Data-Sheet-11-Infineon****IMPORTANT NOTICE**

The information given in this document shall in no event be regarded as a guarantee of conditions or characteristics ("Beschaffheitsgarantie").

With respect to any examples, hints or any typical values stated herein and/or any information regarding the application of the product, Infineon Technologies hereby disclaims any and all warranties and liabilities of any kind, including without limitation warranties of non-infringement of intellectual property rights of any third party.

In addition, any information given in this document is subject to customer's compliance with its obligations stated in this document and any applicable legal requirements, norms and standards concerning customer's products and any use of the product of Infineon Technologies in customer's applications. The data contained in this document is exclusively intended for technically trained staff. It is the responsibility of customer's technical departments to evaluate the suitability of the product for the intended application and the completeness of the product information given in this document with respect to such application.

For further information on technology, delivery terms and conditions and prices, please contact the nearest Infineon Technologies Office ([www.infineon.com](http://www.infineon.com)).

**WARNINGS**

Due to technical requirements products may contain dangerous substances. For information on the types in question please contact the nearest Infineon Technologies Office.

Except as otherwise explicitly approved by Infineon Technologies in a written document signed by authorized representatives of Infineon Technologies, Infineon Technologies' products may not be used in any applications where a failure of the product or any consequences of the use thereof can reasonably be expected to result in personal injury.

## Revision History

Version	Date	Changes
Revision 1.0	2013-01-30	Final Data Sheet
Revision 1.1	2023-01-30	Diagram 8 Typ. drain-source on-state resistance: used $\alpha$ value clarified